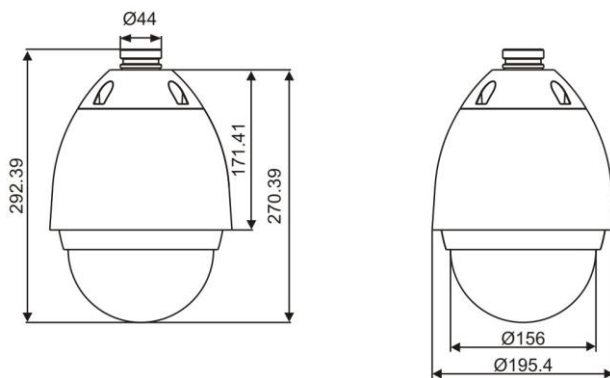

WQP-6018Z**700TVL Speed Dome camera****Key Features**

- ▶ 700TVL 1/3" SONY CCD EFFIO-S
- ▶ 18X optical zoom $f=4.7\sim 84.6\text{mm}$
- ▶ 8 alarm inputs, 2 alarm outputs(optional)
- ▶ Pan: 360° continuous rotation
- ▶ Tilt : 0°~ 90°, Auto Flip 180°to Continue Monitor
- ▶ High Speed: Pan: 0.1~ 360°/s Tilt : 0.1~ 180°/S
- ▶ Work temp : -40°C~+60°C
- ▶ OSD menu : English, Chinese, , Russian, Spanish Optional
- ▶ 8 tracks, preset, speed and dwell time changeable
- ▶ Protocol : PELCO-D, PELCO-P , ULTRACK, VICON, DYNACOLOR

Dimensions**Technical Specification**

Model Name	WQP-6018Z
Sensor	1/3" SONY CCD
Effective Pixels	480K(N); 570K(P)
DSP	EFFIO-S
Horizontal Resolution	700TVL
Min. Illumination	1.0 Iux/0.02 Iux: Slow Shuttle ON (F1.6/30 IRE)
White Balance	Auto, Indoor, Outdoor, Switch Control Auto, Manual
Gain Control	Auto, Manual
Exposure	Auto, Fixed Shuttle, Fixed Iris, AGC, Manual
Brightness	Manual (High/Low)
DNR	3D DNR: OFF, Auto, 1-5 Level; 2D DNR: OFF, 1-4 Level;
Image Stabilization	ON/OFF
Fog Penetrating	OFF, 1-15 Level
S/N Ratio	52dB(AGC off)
BLC	ON/OFF
WDR	OFF, 1-5 Level
Digital Shutter	1/50---1/10000s
Day & Night	ICR
Digital Zoom	12X
Privacy Mask	3D Mode, 8 Zones
Zoom Mode	Auto/Manual
Focal Length	4.7mm~84.6mm, 18X Optical Zoom
Zoom Speed	4.5S(1-18X)
Horizontal Angle of View	54.8~3.4° (Wide~Tele)
Minimum Object Distance	10-1000mm (Wide~Tele)
F-Value	F1.6-F2.7
Preset position	256 Preset Positions
Pattern	6 Lines(Pan/Tilt/Zoom, every line can record up to 120 seconds)
Address range	0~255 (Setup by dip switcher, firmware)
Communication	RS485 (+/-)
Baud rate	2400/4800/9600/19200
Ingress protection	IP67
Work temp	-40°C~+60°C
Work humidity	0%~90%
Power	AC24V/2.5A
Weight	4.2KG